



Aircraft Surveillance Systems

Marilake has developed its *flightmaster Sentry* aircraft surveillance system to enable the crew to monitor activity onboard the aircraft. Although primarily aimed as a cockpit door integrity system the system is highly adaptable with cameras and crew monitoring VDUs mountable throughout the aircraft.



Capabilities

Monitor air incidents and activity during flight.

Positively identify crew members outside of the cockpit door in all light conditions. Cameras and VDUs can be mounted anywhere inside the aircraft including the baggage hold areas.

VDU units are Arinc rail mountable for easy cockpit installation.

Dual VDUs for pilot and co-pilot use.

Any number of cameras can be installed and independently configured using the VDU.

Monochrome with Infra Red cameras for low-light conditions or colour cameras can be used interchangeably.

System provides audio from microphones mounted inside the camera housing.

Products released on EASA Form 1.

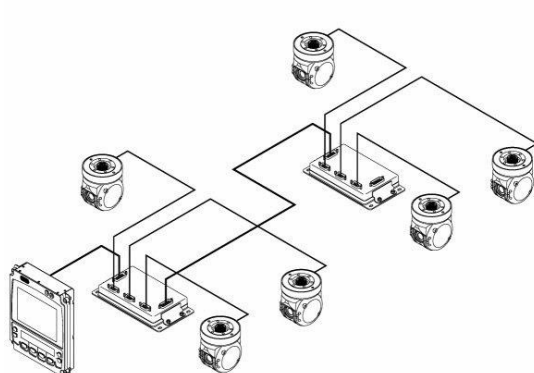

Further Information

Contact Marilake for more information on +44 (0) 1202 863747

Or visit our website at www.marilake.com